

JVC

SERVICE MANUAL

DVD VIDEO PLAYER

XV-S40BK / XV-S42SL XV-S45GD / XV-S30BK

Supplement

Area Suffix
(XV-S40BK/XV-S30BK)

J ----- U.S.A.

C ----- Canada

Area Suffix (XV-S42SL)

C ----- Canada

Area Suffix (XV-S45GD)

J ----- U.S.A.

This supplement has described the mechanism adjustment method.

Please adjust mechanism according to the description method when you exchanged picking up.

■ Flap adjustment of the pick-up guide shaft

<Tool list for adjustment>

- Stud (four pieces set)
Parts No. : JIGXVS40
- Extension cord set (two cord and two board)
Parts No. : EXTXVS40CB
- Hex wrench for adjustment
Off-the-shelf (1.3mm)
- Test disc
VT-501 or VT-502

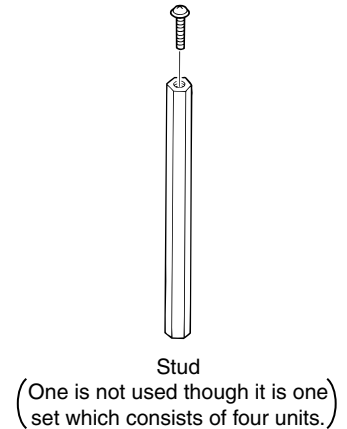
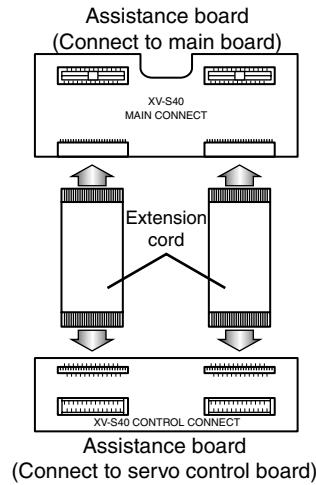

<Adjustment preparation>

1. The mechanism assembly is made in the state from the main body from which is detached referring to the disassembly method.
2. Three studs are installed in the mechanism assembly respectively.
3. The servo control board is removed from the mechanism assembly, and puts into the state set up as shown in figure. (Each wire connected by the servo control board this time leaves the connection maintained.) Between shaft and hook of mechanism assembly of figure Board is put And, the board is inclined in the direction of the arrow on figure as much as possible.
4. The extension cord is inserted in the connector of the assistance board respectively. The main board is connected with the servo control board as shown in figure.

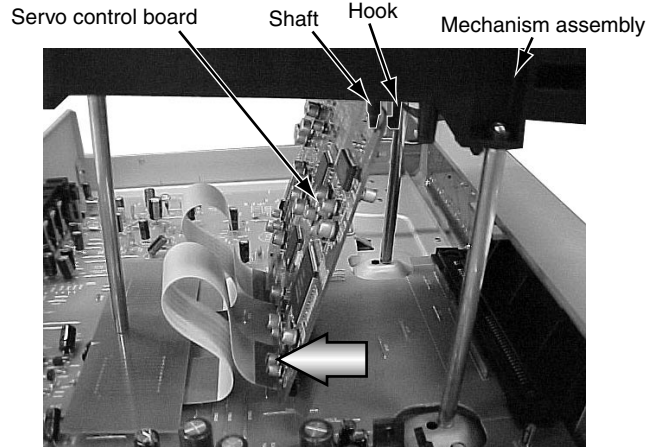
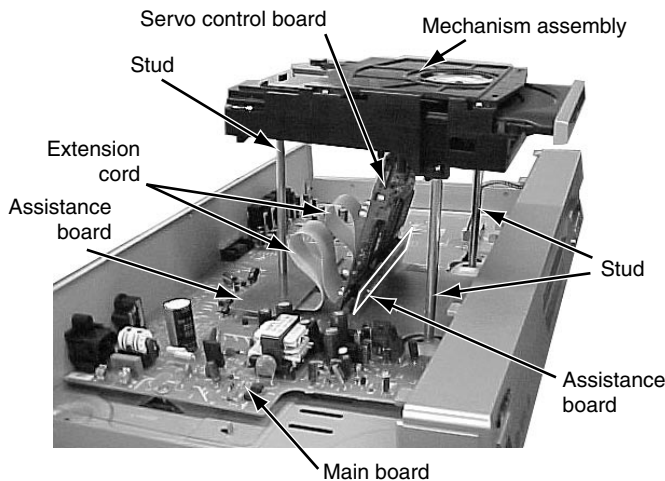

<Adjustment>

1. Puts into the state to display the jitter value on the FL display referring to "For jitter value".
2. The adjustment screw under the traverse mechanism is turned with hex wrench, and matches so that the jitter value displayed on the FL display may become minimum value.

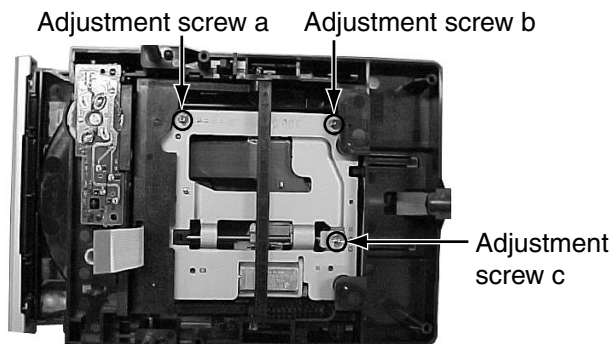

<POINT>

1. turns in the forward or the opposite direction, and makes to the position where the jitter value is good the half rotation of adjustment screw a and b(180 degrees) respectively.
2. Afterwards, adjustment screw b and c are turned in the same way, and makes to the best position.

XV-S40BK/XV-S42SL
XV-S45GD/XV-S30BK

JVC

VICTOR COMPANY OF JAPAN, LIMITED
PERSONAL & MOBILE NETWORK BUSINESS UNIT
1644, Shimotsuruma, Yamato, Kanagawa 242-8514, Japan